

# **PENTAX**

---

## **AUTOMATIC LEVEL AL SERIES**

---

**AL-240·AL-240R·AL-270·AL-270R  
AL-300·AL-320·AL-320R·AL-320s**

---

## **INSTRUCTION MANUAL**

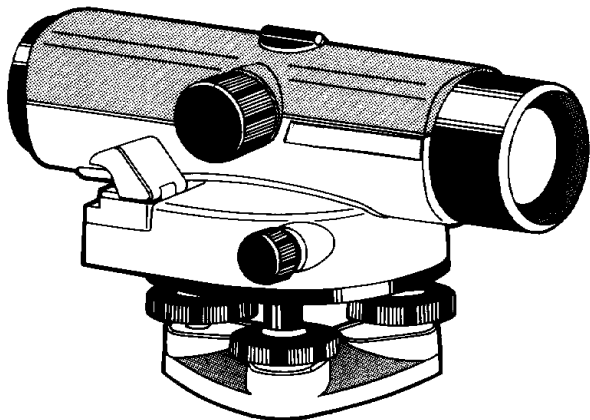

**ASAHI PRECISION CO., LTD.**

## **(For proper operation of instrument)**

The Pentax automatic levels AL-series (AL-240, AL-240R, AL-270, AL-270R, AL-300, AL-320, AL-320R and AL-320s) consist of a variety of instruments in order to comply with a wide range of surveying from second or third order leveling surveying to civil engineering requiring high accuracy.

Our surveying instruments are precise in function and precision made. Surveying instruments do not either work well nor become of value unless they are carefully handled and operated. For the instrument to work efficiently and be useful for long time, read through this instruction book.

### **Storage**

This instrument should be stored in a dry, dust-proof room, which does not have a big temperature range. When the instrument is stored for a long time, it must occasionally be taken out of the case and air circulated freely around the instrument. When storage or transportation temperature is extremely different from the working temperature, the instrument must be allowed to come to the ambient temperature. Exposure time required is approximately one minute per one degree temperature difference.

### **Transport**

For shipment, the instrument should be packed with cushioning material with reasonable thickness on all sides. Insurance coverage is recommended. Vehicle transportation does not require packing but movement should be restricted by securing it. When heavy vibration or rough travel is encountered, it is recommended that the instrument be secured in a padded box.

### **Checking**

Before measurement, an instrument should be examined according to this instruction book. If necessary, the instrument should be adjusted. Even a new instrument or completely repaired instrument needs to be checked. This procedure is also recommended during long intervals of non-use or after long journey. At least once per year, or more often, it is recommended that the instrument should be checked by a qualified Pentax dealer.

## Unpacking

When removing an instrument from its carrying case, pay attention to how it is positioned so that it can be returned properly. Grasp the instrument securely when removing or returning it from or to the case.

## Setting up

When installing or removing the instrument on or from the tripod, the instrument should be securely held with one hand while the other hand manipulates tripod center screw. The instrument should never be left on the tripod without being fastened down. Failure to carry out these instructions can result in a bad accident. Careful operation and handling of the instrument in accordance with these instructions and plain common sense will provide long and useful service.

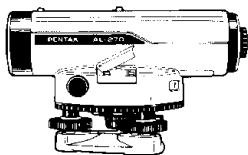

**AL-240** (24X Foot screw type)

**AL-270** (27X Foot screw type)

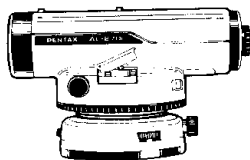

**AL-240R** (24X Spherical base type)

**AL-270R** (27X Spherical base type)

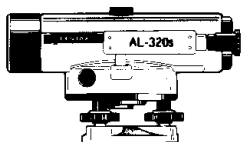

**AL-320S** (32X Foot screw type w/Glass circle)

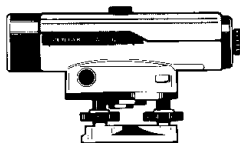

**AL-300** (30X Foot screw type)

**AL-320** (32X Foot screw type)

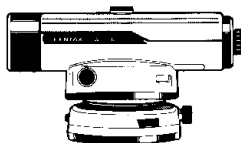

**AL-320R** (32X Spherical base type)

## Contents

<b>1. Features</b> .....	4
<b>2. Description</b> .....	5
<b>3. Equipment</b> .....	6
<b>4. Specifications</b> .....	7
<b>5. Operation</b>	
<b>1</b> Preparation for surveying	
1) Setting up the tripod .....	9
2) Setting up the instrument .....	9
3) Levelling .....	10
<b>2</b> Observation	
1) Reticle collimation .....	10
2) Sighting .....	11
3) Reading the staff .....	12
<b>3</b> Surveying	
1) Leveling .....	12
2) Stadia survey .....	13
3) Angle measurement .....	14
<b>6. Maintenance and packing</b>	
<b>1</b> Maintenance .....	15
<b>2</b> Packing .....	15
<b>7. Precaution</b> .....	16
<b>8. Inspection and adjustment</b>	
<b>1</b> Circular level .....	16
<b>2</b> Leveling line of sight .....	17
<b>9. Optional accessories</b>	
<b>1</b> Electric illumination device [EP2] .....	19
<b>2</b> Diagonal eyepiece [SBL2] .....	20
<b>3</b> Parallel plate micrometer [SM4] .....	21

## 1. Features

- With special alloy ribbon with long-established reputation, a newly developed automatic compensator is of wire-suspension type and provides extremely stable surveying results even under unfavorable conditions such as vibration.
- Minimum focus distance is extremely short, 0.3m/12 inches on the AL-240 and AL-270, and 0.5m/20 inches on the AL-300, AL-320 and AL-320s. Anallactic optics of the telescope makes stadia surveying easy as the stadia constant is 0.
- Telescope section is dust and water-proof. Work is possible even in the rain or in high humidity conditions.
- The instrument can be installed on a flat-head or domed-head tripod.
- The telescope rotates about a vertical axis controlled by a clampless friction drive. Tangent screw can be operated either by right or left hand as it has knobs on both sides.
- The AL-320s with a glass circle graduated down to 10' or 10cc permits angle measurements with the higher accuracy. Fine-coarse focussing screw provides fast and accurate focussing.
- The illumination device, diagonal eyepiece and parallel plate micrometer are available as optional accessories.

## 2. Description

Gunsight collimator (AL-240/AL-270)  
Optical collimator (AL-300/AL-320/AL-320S)

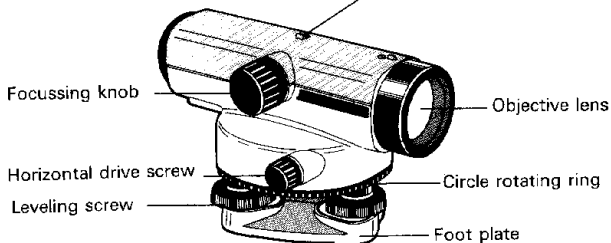

**AL-240/AL-270/AL-300/AL-320/AL-320S**

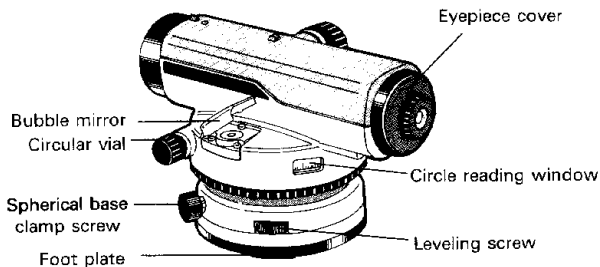

**AL-240R/AL-270R/AL-320R**

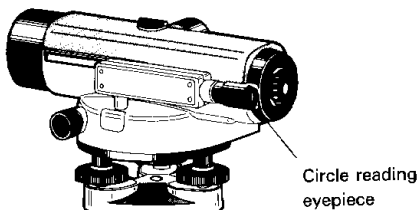

**AL-320S**

Note: The illustrations are of the AL-240 and AL-240R. Designs of the AL-300, AL-320 and AL-320S differ.

### 3. Equipment

#### 1 Standard equipment

① Instrument .....	1
② Carrying case .....	1
③ Objective cap .....	1
④ Plumb bob .....	1
⑤ Hexagonal wrench .....	1
⑥ Brush .....	1
⑦ Rain cover .....	1
⑧ Silicon cloth .....	1
⑨ Instruction manual .....	1

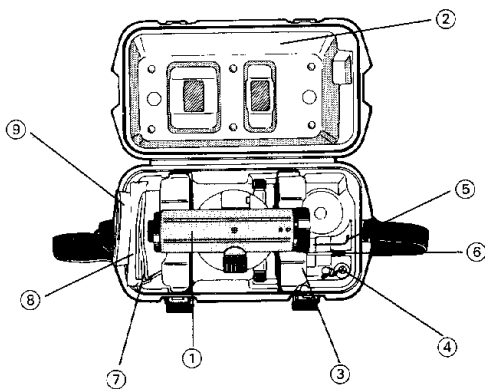

#### 2 Optional accessories

Tripod (TS-3, TS-10, TS-10F) Diagonal eyepiece (SBL2)

Electric illumination device (EP2)

Parallel plate micrometer (SM4)

#### 4. Specifications

	AL-240	AL-240R	AL-270	AL-270R
Telescope	Internal anallactic optics			
Image	Erect			
Magnification	24X		27X	
Objective aperture	36mm		40mm	
Resolving power	3.5"		3"	
Field of view	2.5% (1'26')			
Minimum focus distance	0.3m/12 inches			
Stadia ratio	1 : 100			
Stadia constant	0			
Automatic compensation				
Compensation range	± 12'			
Setting accuracy	± 0.5"			
Standard deviation ※ (1 Km duple run leveling) ※※	± 2.0mm		± 1.5mm	
Sensitivity of vial				
Circular vial	8'/2mm			
Horizontal circle	Metal			
Diameter	96mm			
Graduation	1'/1G			
Estimation	0.1'/0.1G			
Leveling base	3 screw	Spherical	3 screw	Spherical
Dimensions and weight				
Length(mm)	219			
Width(mm)	147			
Height(mm)	133	137	133	137
Weight(kgs./lbs)	1.6/3.5	1.8/3.9	1.6/3.5	1.8/3.9
Carrying case(mm)	364(L) × 200(W) × 180(H) 1.5kgs./2.3lbs			

AL-300	AL-320	AL-320R	AL-320S
Internal anallactic optics			
Erect			
30X	32X		
42mm	45mm		
3"	2.5"		
2.3% (1'20')			
0.5m/20 inches			
1 : 100			
0			
±12'			
±0.3"			
±1.0mm	±0.8mm		
±0.5mm	±0.4mm		
8'/2mm			
Metal		Glass	
96mm		88mm	
1'/1G		10'/10c	
0.1'/0.1G		1'/1c	
3 screw	Spherical	3 screw	
247			
147			
137	141	137	
1.8/3.9	2.0/4.4		
364(L) × 200(W) × 180(H) 1.5kgs./2.3lbs			

※ Standard deviation measured without the parallel plate micrometer

※※ Standard deviation measured with the parallel plate micrometer

## 5. Operation

### 1 Preparation for surveying

#### 1) Setting up the tripod

- ① Prepare the tripod having a center locking screw with 5/8"×11 thread.
- ② Dig the legs firmly into the ground and adjust the tripod to the height suitable for observation when the instrument is mounted.
- ③ For angle measurement, set the tripod so that the center of the tripod head is positioned right above the ground point.

#### 2) Setting up the instrument

- ① Mount the instrument on the tripod head and secure it using a center lock screw.
- ② Suspend the plumb bob from the hook, adjusting the length of the string. (for angle measurement)
- ③ Loosening the center lock screw, move the instrument with the tips of fingers. Tighten it as a tip of plumb bob coincides with the ground point. (for angle measurement)

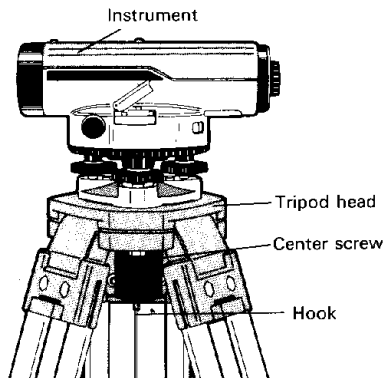

### 3) Leveling

- ① Place the telescope in parallel to the line connecting two optionally selected leveling screws, and turn them to move the bubble of the circular level at a position even to the left and the right. (Fig. A)
- Turn the **two** leveling screws in **opposite** directions.
- ② Turning a remaining leveling screw, shift the bubble to the center. (Fig. B)
- ③ Make sure that the bubble stays at the center of the circle even after turning the telescope  $180^\circ$ .
- See arrows in Fig. A and B for the relation between the direction of leveling screw rotation and the bubble shifting direction.
- If the bubble is out of the center in ③, "adjustment of the circular level" on page 16 is needed.

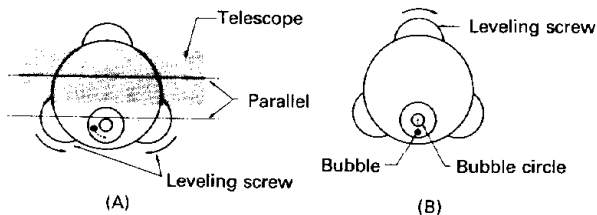

## 2) Observation

### 1) Reticle collimation

- ① Remove the objective cap. If necessary, attach the sunshade.
- ② Directing the telescope to the bright background, rotate the eyepiece counterclockwise to draw out the eyepiece ring.
- ③ While looking into the eyepiece, rotate it clockwise until the cross hair of the reticle comes to its extreme sharpness.
- It is advisable to relax when looking into the eyepiece. An intense look at the reticle may tend to cause parallax or eye fatigue.

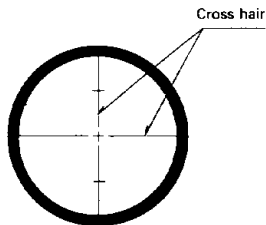

## 2) Sighting

- ① Sight the telescope at the object looking through the collimator.
- ② Looking into the eyepiece, rotate the focussing knob until the objective becomes clearly visible. Make sure that the relation between the object and the cross hair does not change even when you move your eye up or downward.

■ If parallax exists in ②, the relation between the object and the cross hair may change. This may cause surveying error.

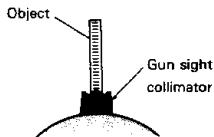
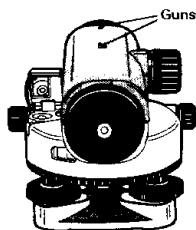

AL-240/AL-270

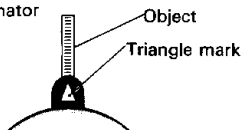
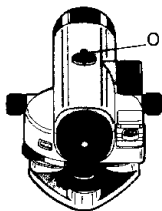

AL-300/AL-320/AL-320S

### 3) Reading the staff

How to read the graduation on the staff.

Reading value 2.195m

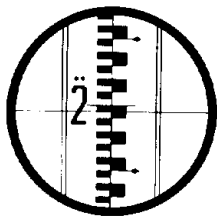

- Reading of the staff should be done at the center of the cross hair on the reticle.

### 3 Surveying

#### 1) Leveling

- How to get the difference in height and the elevation

Difference in height ( $\Delta h$ ) = backsight (b) – foresight (f)

**Elevation at point B ( $h_b$ )** = Elevation at point A ( $h_a$ ) +  $\Delta h$

S (I): Staff (I)

S (II): Staff (II)

I: Instrument

B.S: Backsight (Staff reading at the point where elevation is specified.)

F.S: Foresight (Staff reading at the point where elevation is unspecified.)

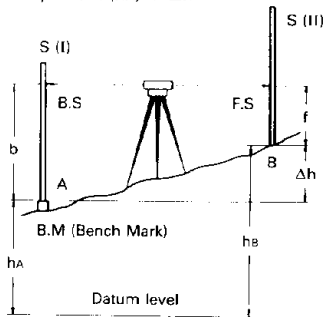

$$\begin{aligned} \text{Difference in height } (\Delta H) &= \Sigma \Delta h \\ &= \Sigma b - \Sigma f \end{aligned}$$

$$\text{Elevation } H_B = H_A + \Delta H$$

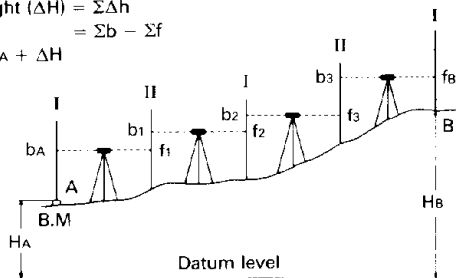

- Set the instrument at almost middle of two staffs.
- When reading the staff, try to get least reading by tilting the staff back and forth slightly.
- For more precise surveying, use the double run method.

## 2) Stadia survey

Distance from the instrument to the staff can be measured by the stadia hairs visible within the field of view of the telescope.

- To measure the distance is easy as stadia constant is 0.

S: Horizontal distance

$\ell$ : Difference in reading between of upper and of lower stadia lines

$$S = 100 \ell$$

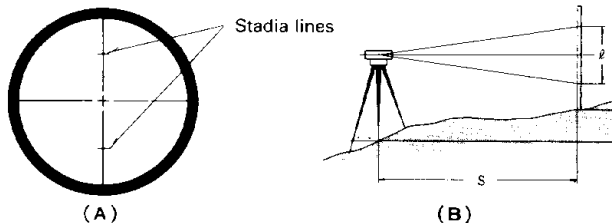

### 3) Angle measurement

Models equipped with a horizontal circle are capable of horizontal angle measurement or setting.

#### ■ Example

(All models excluding AL-320S)

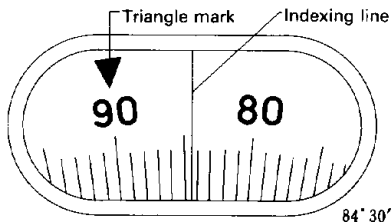

(AL-320S)

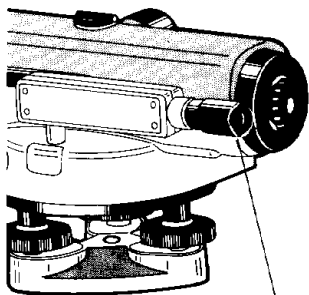

Circle reading  
eyepiece



$127^{\circ} 25'$

- When reading horizontal angle, be sure and put yourself just in front of it.
- Make use of symbol ▲ marked every  $90^{\circ}$  or 100G for right angle setting.

## **6. Maintenance and packing**

### **1 Maintenance**

- ① Clean dust or water from the instrument and then put it back to the case after using it.
- ② Brush dust off, wipe off moisture on exposed parts with a soft cloth.
- ③ Wipe off the moisture on the surface of the lenses with a cotton cloth, using light pressure, after brushing the dust off.

### **2 Packing**

- ① Gently put the instrument into the case, facing focussing knob toward you.
- ② Close the case and secure the latch.

## 7. Precaution

- ◇ Operate the instrument carefully. Do not apply excessive pressure to it.
- ◇ Store the instrument in a dry place, removing dust or moisture after use of it.
- ◇ Be careful not to subject the instrument to impact or vibration during transport.
- ◇ When moisture or disorder is found inside the lens, contact your dealer, do not attempt to dismantle the instrument by yourself.
- ◇ When any malfunction due to falling down or some other cause is recognized, contact your dealer, do not attempt to forcibly dismantle the instrument by yourself.
- ◇ Check all parts of the tripod are firmly secured.

## 8. Inspection and adjustment

### 1 Circular level

#### 1) Inspection

- ① Setting the instrument on the tripod, level it so that the bubble of circular level is positioned at the center of the circle. (Refer to P.10 "Leveling".)
- ② Turn the telescope 180°.
- ③ No further adjustment is necessary if the bubble stays at the center of the circle.

#### 2) Adjustment

- ① If the bubble moves out of the center in the circle, turn the levelling screw to shift the bubble halfway back after taking off the bubble mirror. (Fig. A)
- ② Shift the bubble remaining halfway to the center by turning adjustment screws. (Fig. B)
- ③ Turn the telescope 180° to check to see if the bubble stays at the center of the circle.
- ④ Repeat again from ① should the bubble move.

- When doing adjustment, finish screws being firmly tightened.

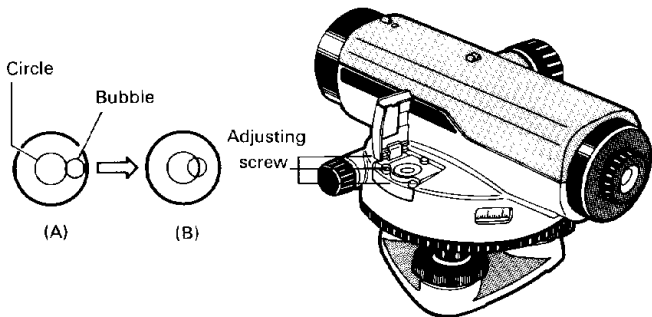

## 2 Leveling line of sight

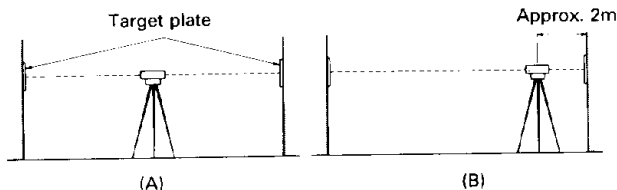

### 1) Inspection

- ① Prepare two same target plates. Setting up the instrument midway between two walls at a distance of 50 to 100 meters, level it. (A)
- ② Sighting both walls alternately, adjust the target plates to the height so that readings of the target plates are identical, and secure them in position.
- ③ Move the instrument to a position approx. 2 meters from one target plate and level it. (B)
- ④ Read both target plates.
- ⑤ No adjustment is necessary if readings of both target plates are identical.

## 2) Adjustment

- ① Aim the telescope at the farthest target plate in case that readings of both target plates are not identical.
- ② Remove the eyepiece cover, rotate the reticle adjusting screws with the adjusting pin and adjust the reading to be identical to that of the other target plate.
- ③ Repeat procedures from "Inspection ④" and check if adjustment is correct.

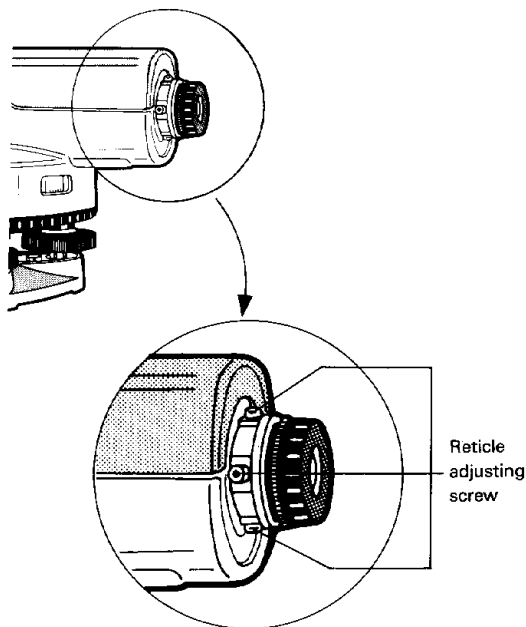

## 9. Optional accessories

### 1 Electric illumination device [EP2]

Electric illumination device permits surveying work in a tunnel or any dark place by way of illuminating the reticle.

Light source ..... Green LED  
Power supply ..... Two 1.5V dry batteries (SUM-3)

- ① It can be mounted in the same way that a sunshade is attached to the telescope objective.
  - ② Turn the switch on and adjust brightness by rotating illuminator knob while looking into the telescope.
- Remove battery when device will not be used for an extended period as extended storage may cause damage to the device due to leakage of battery acid.

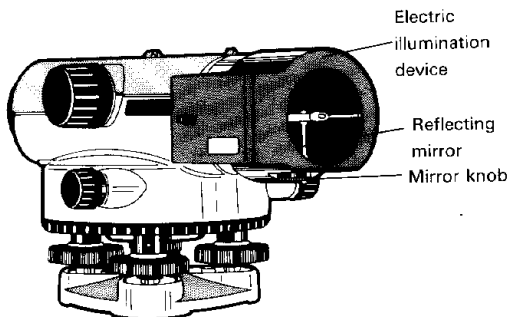

## 2 Diagonal eyepiece [SBL2]

Diagonal eyepiece[SBL2] is to be used for surveying in a limited space or when the instrument is set at a lower position where it is hard to look into the telescope.

### Operation

- ① Remove the eyepiece cover, turning it counterclockwise.
  - ② Screw the diagonal eyepiece in to the attaching screw of the eyepiece cover.
  - ③ Looking into the eyepiece lens of the diagonal eyepiece, collimate the reticle.
- Prior to attaching the diagonal eyepiece to the instrument, collimate the reticle with eyepiece mounted on the telescope.

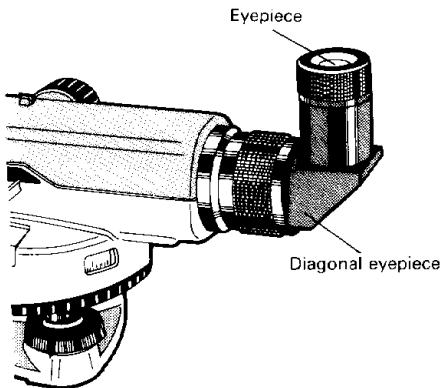

### 3 Parallel plate micrometer [SM4]

The parallel plate micrometer is used for leveling or civil engineering work requiring precise accuracy. With a bright microscale etched on an optical glass, it provides reading down to 0.1mm.

#### Operation

- ① Mount the parallel plate micrometer horizontally on the head of the telescope and the counterweight on eyepiece of the telescope. Then, secure the both.
- ② Turning the micrometer knob, accurately put the staff graduation between the wedged-shaped lines.
- ③ Read the staff (A) and microscale (B).

#### Note :

- When using the parallel plate micrometer, replacement of the standard reticle with a wedge-pattern reticle is recommended. (Contact your local dealer for replacement.)
- It is also recommended that a precision reading staff be used to achieve full performance of the parallel plate micrometer.

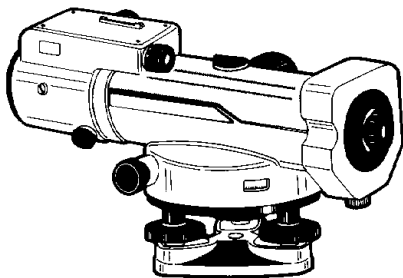

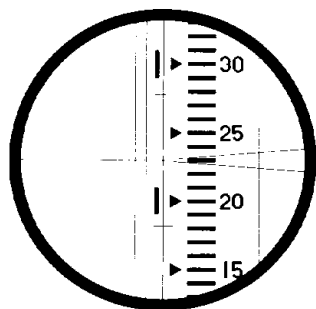

(A) Staff

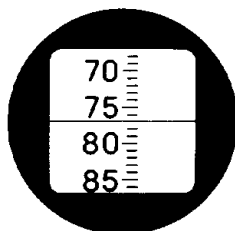

(B) Microscale

Example:

Staff reading ..... 123.00cm

Micrometer reading ..... 0.77cm

---

123.77cm

# PENTAX

**ASAHI PRECISION CO., LTD.**

1-1-21, Shirako, Wako-Shi,  
Saitama-ken, 351-01, Japan

12.1993 First edition

20.12.1994 Second edition

**AL00102E**

Printed in Japan